

WARPING ROLLERS DIN81906

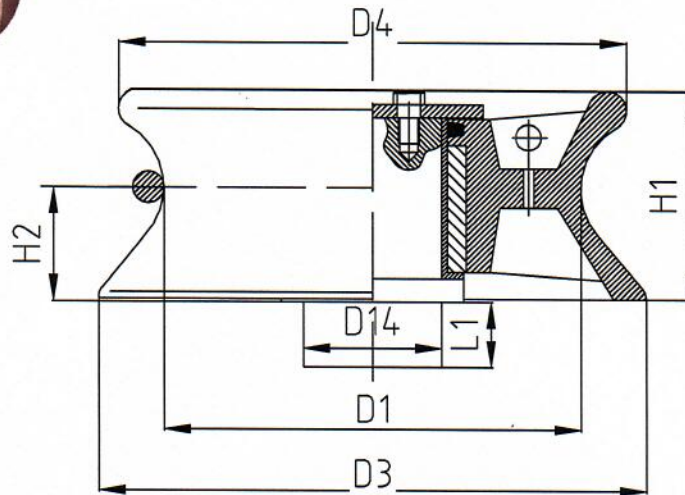

Standard finishing: shot blasted, 1 layer of shop primer

Type	Pull Force (kN)	Wire ϕ	D1	D3	D4	D14	H1	H2	L1	Weight (kg)
1	10	12	160	210	195	60	80	42	50	14
2	20	16	200	265	245	70	102	56	50	20
3	30	20	250	330	300	85	126	71	50	33
5	50	24	320	420	390	106	160	88	50	72
8	80	32	400	530	490	125	208	113	60	140
12	120	40	450	610	560	160	256	139	85	240
20	200	48	500	640	620	190	278	144	100	320
32	320	48	560	780	740	230	348	183	150	580

Dimensions in mm, alterations may occur.



Lemans Nederland B.V.
Canadaweg 8
4661 PZ Halsteren
The Netherlands

Tel.: +31(0) 164 680097
Fax: +31(0) 164 681971
E-mail: info@lemans-nederland.eu
Website: www.lemans-nederland.nl